

Rev	Date	Description	By
B	26-10-23	SINGLE SIDED VERSION & P3 ADDED	JAS
A	21/7/23	ORIGINAL ISSUE	MJS

Client
NATIONAL PARKS - IRELAND

Detail
CAR PARK DIRECTIONAL & INFO SIGNS - TYPE B2

Site
N/A

Material
Material <not specified>

Component weight
116.85 kg

Drawn by	Checked by	Scale
MJS		1:8

Drawn date	Checked date	Approved for Manufacture
21/7/23		X

01392 444501
www.wsigns.co.uk

No part of this drawing & the design contained herein may be reproduced without the written consent of Wood & Wood Signs

Drawing number	Rev
24440	B

Sheet 1 of 3

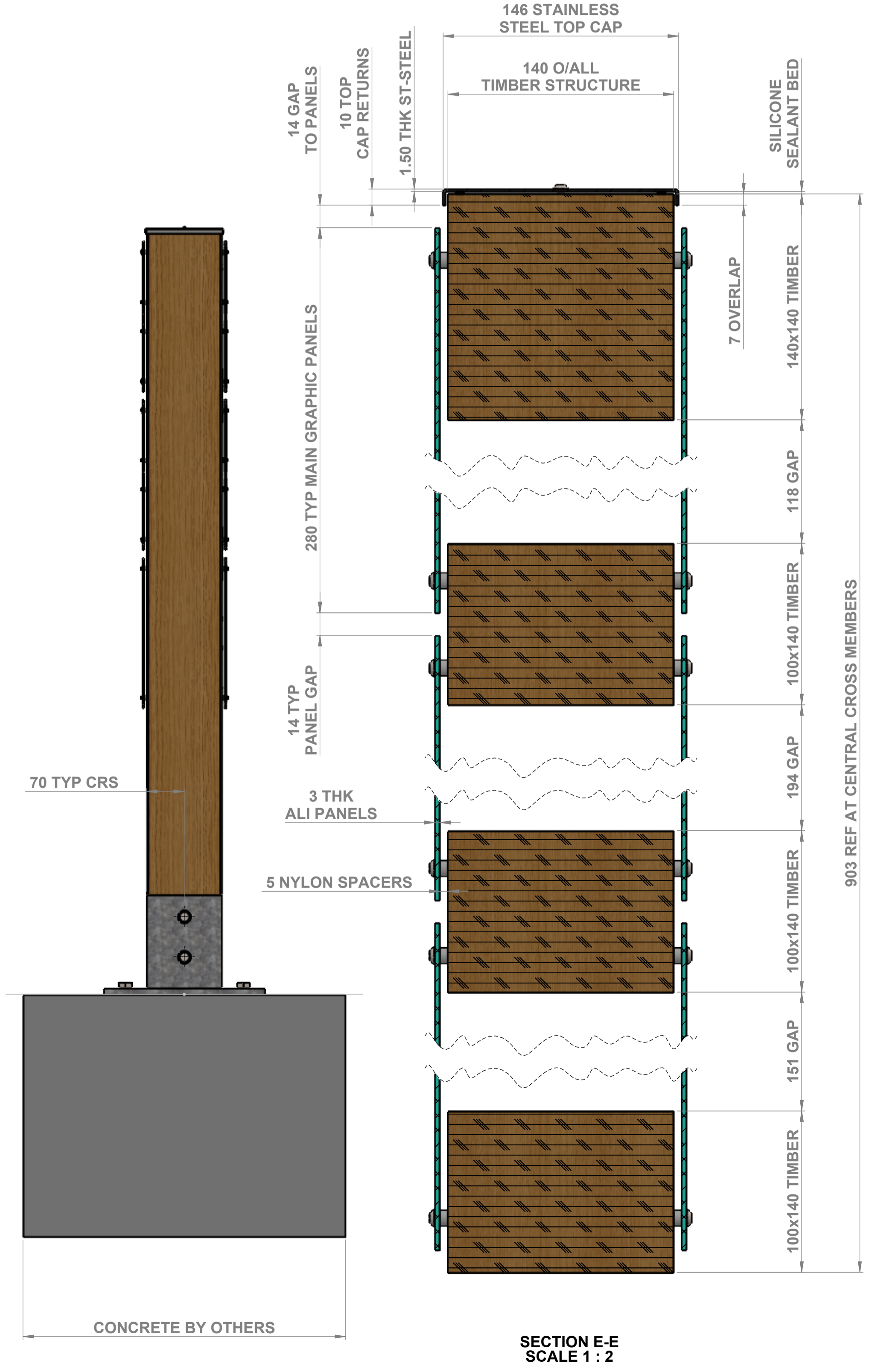
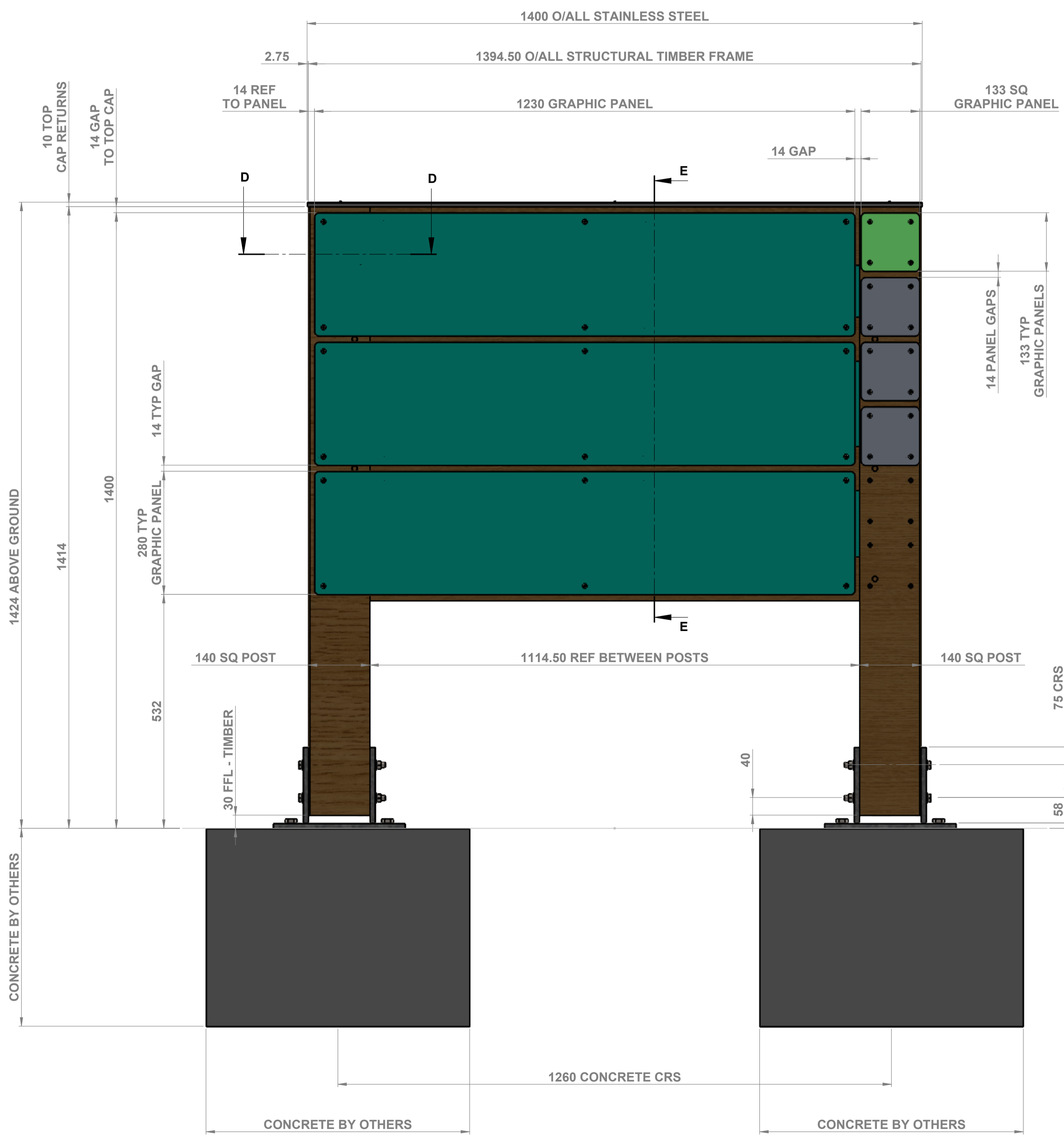
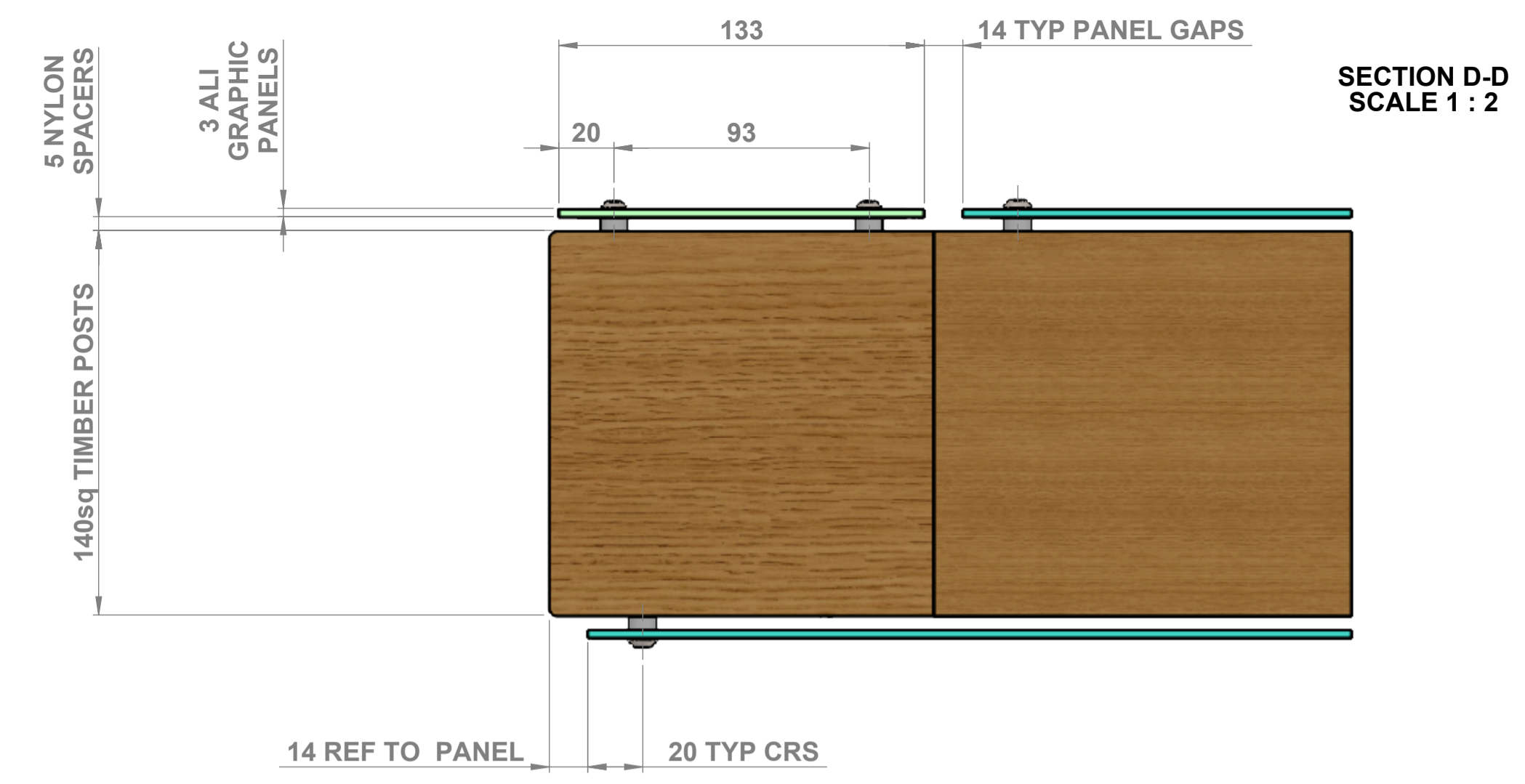
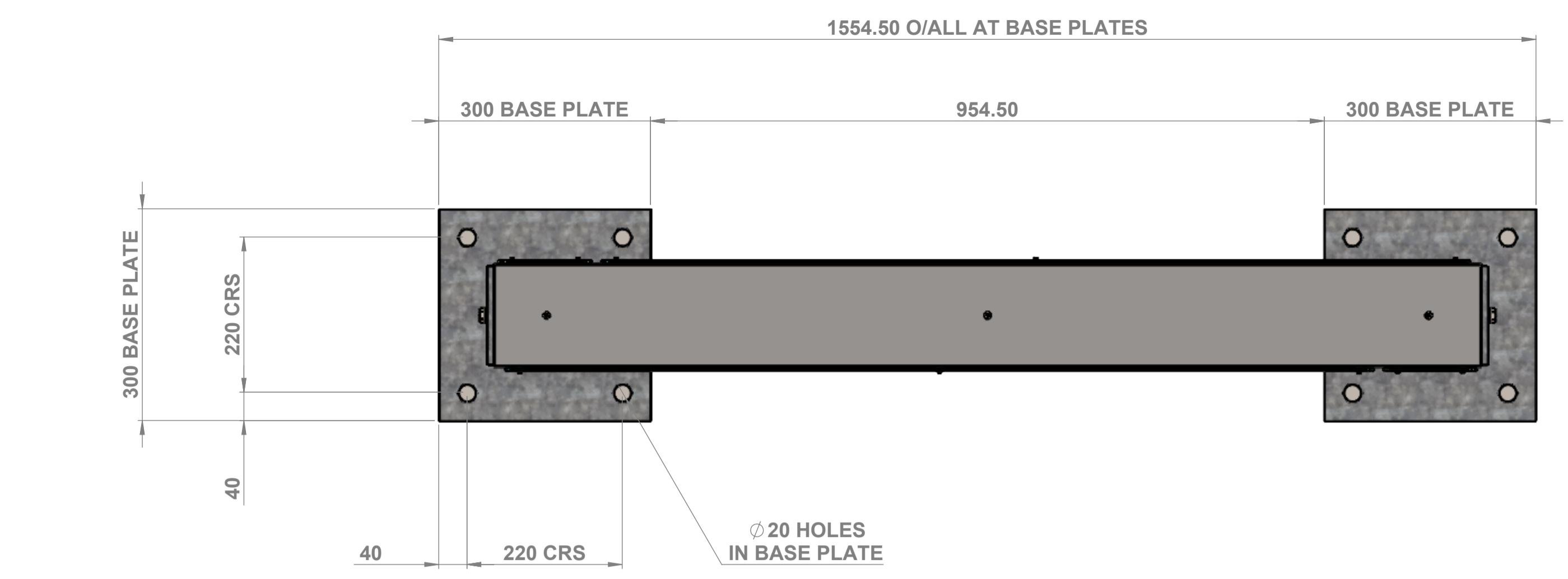

Rev	Date	Description	By
B	26-10-23	SINGLE SIDED VERSION & P3 ADDED	JAS
A	21/7/23	ORIGINAL ISSUE	MJS

Client
NATIONAL PARKS - IRELAND

Detail
CAR PARK DIRECTIONAL & INFO SIGNS - TYPE B2

Site
N/A

Material
Material <not specified>

Component weight
129.77 kg

Drawn by MJS	Checked by	Scale 1:6
Drawn date 21/7/23	Checked date	Approved for Manufacture X

Wood & Wood International Signs Ltd
Heron Road
Sowton Industrial Estate
Exeter
Devon
EX2 7LX
01392 444501
www.wsigns.co.uk

No part of this drawing & the design contained herein may be reproduced without the written consent of Wood & Wood Signs

Drawing number 24440	Rev B
Sheet2 of 3	

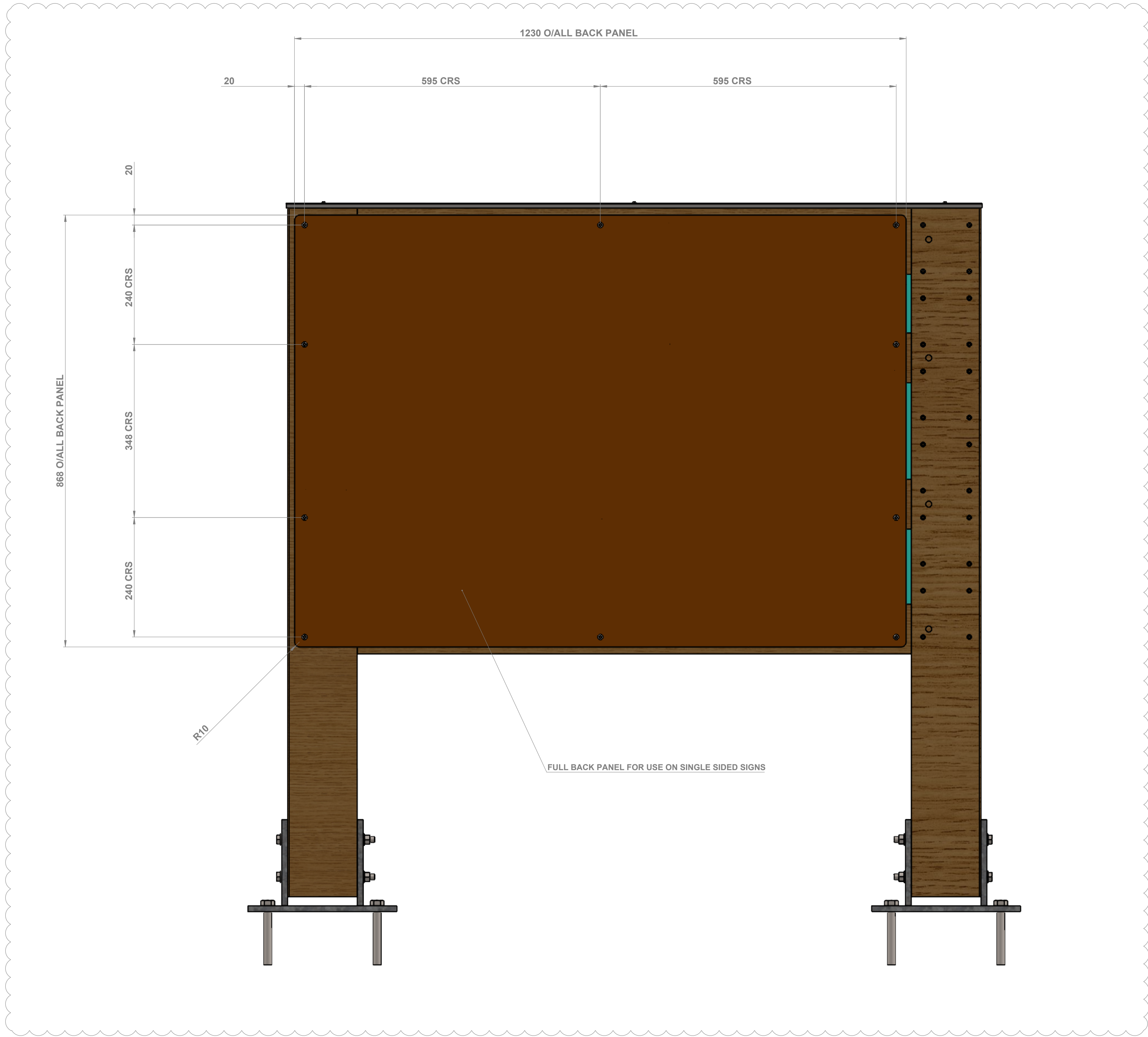

Rev	Date	Description	By
B	26-10-23	SINGLE SIDED VERSION & P3 ADDED	JAS
A	21/7/23	ORIGINAL ISSUE	MJS

Client
NATIONAL PARKS - IRELAND

Detail
CAR PARK DIRECTIONAL & INFO SIGNS - TYPE B2

Site
N/A

Material
Material <not specified>

Component weight
116.55 kg

Drawn by MJS	Checked by	Scale 1:4
Drawn date 21/7/23	Checked date	Approved for Manufacture X

WW
Wood & Wood International Signs Ltd
Heron Road
Sowton Industrial Estate
Exeter
Devon
EX2 7LX
01392 444501
www.wwsigns.co.uk

No part of this drawing & the design contained herein may be reproduced without the written consent of Wood & Wood Signs

Drawing number 24440	Rev B
Sheet 3 of 3	